

BICERA™ SIGMA Explosion Relief Valve



General Description

The BICERA™ Sigma Valve by HOERBIGER Safety Solutions offers a reliable, integrated safety solution with quick pressure relief capabilities. Designed in seven industry-standard sizes and approximately 25% smaller than traditional options, this innovative valve provides engine designers with unmatched flexibility to incorporate additional features. Weighing about half as much as conventional valves, the BICERA™ Sigma Valve reduces the impact of vibrations, enhancing operational efficiency.

Key Features

- Most compact ERV on the market
- Roughly half the weight of existing products on the market
- Unique and patented flame arrester design
- Exceptional flame suppression, which offers great potential even when using alternative fuels such as Hydrogen
- IACS UR M66 Certified

Application

Explosions can occur in the crankcase of combustion engines, as well as large compressors, gearboxes and transmissions. Internal components of these devices cause the oil to form an oil mist throughout the confined spaces. In the case of gas or dual-fuel engines, gas can also escape into the crankcase or other confined spaces of these applications creating a dangerous environment for explosions. The use of relief valves is a proven way to mitigate equipment damage from overpressure and flame and prevent injury to personnel.

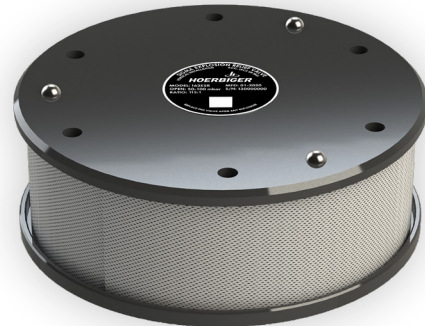

Technical Data

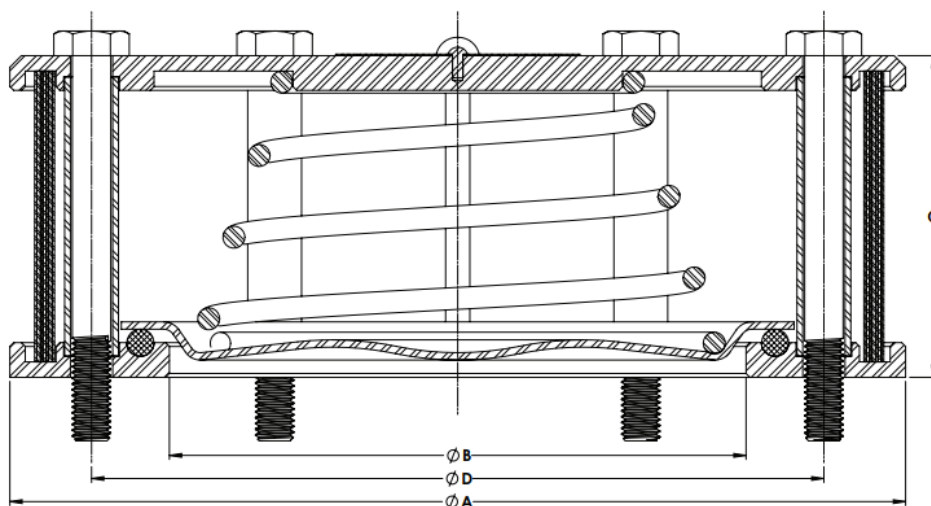

Type	Relief Area [cm ²]	Dimensions			Connection		
		ØA (mm)	ØB (mm)	C (mm)	No. of bolts	Thread	ØD (mm)
98 ESR	59.4	163	87	56	4	M8 or 5/16"	122
122 ESR	95	192	110	66	6	M10 or 3/8"	150
150 ESR	143	222	135	77	6	M10 or 3/8"	180
162 ESR	177	233	150	83.5	6	M10 or 3/8"	190.5
173 ESR	201	249	160	94	6	M10 or 3/8"	203
224 ESR	346	318	210	115.5	6	M12 or 1/2"	255
266 ESR	499	376	252	134	6	M12 or 1/2"	302

Contact Information

Europe, UK, Africa & Middle East:

HOERBIGER Wien
T: +43 1 22440 2290
Sales.ev@hoerbiger.com

China:

HOERBIGER (Shanghai) Co., Ltd.
Tel: 0086-21 6485 0855
info-cn-safety@hoerbiger.com

North & South America:

HOERBIGER
T: +1413.896.1485
Sales.ev@hoerbiger.com

Japan:

HOERBIGER NIPPON K.K.
T +81 476-37-3762
info-hnkk-oem@hoerbiger.com

Korea:

HOERBIGER Korea Ltd.
T: +82-2-431-5867
info-hsk@hoerbiger.com

HOERBIGER

HOERBIGER Wien GmbH
Seestadtstraße 25, 1220
Vienna, Austria

Tel.: +43 1 22440 2290
E-mail: sales.ev@hoerbiger.com
www.hoerbiger.com

